



## Application Brief: Flawless HD Video and Voice over WiFi Networks (at last!)

Premise: Anagran Fast Flow Technology™ enables perfect-quality High Definition (HD) Video, Voice, and transactional data to co-exist over WiFi Networks.

Challenge: Voice and Video over WiFi suffer degraded quality when other applications contend for capacity.

Attempting to run video and voice along with non-interactive data traffic over WiFi networks (or WLAN) poses two significant challenges. The first is overcoming the issue of contention for limited capacity over the air interface. The second is the lack of QoS controls to address real-time, delay-sensitive traffic such as VoIP and video. Let's take a closer look at these challenges.

**Limited Wireless Capacity:** Consisting of wireless access points (APs) and/or AP controllers, WLAN access bandwidth is fixed and limited. Unlike with non-wireless access networks (LAN or WAN), throwing more bandwidth and hardware at the problem may likely make little or no difference. Moreover, WiFi protocols add extra overhead to combat interference and other noise. The challenge therefore is in preserving quality for streaming and interactive traffic over this limited WiFi access.

**Lack of QoS Controls:** Non-interactive traffic contends with voice and video for WiFi access bandwidth. It will often destroy the quality of voice and video in the absence of real-time QoS controls. In addition, inherent delay with WiFi that impacts real-time traffic quality must be addressed to preserve high QoS levels.

**Solution – Anagran makes streaming video, voice, and legacy applications work together over WiFi access networks.**

Anagran Fast Flow Technology™ (FFT) sustains high video and voice quality over WiFi while improving transactional performance.

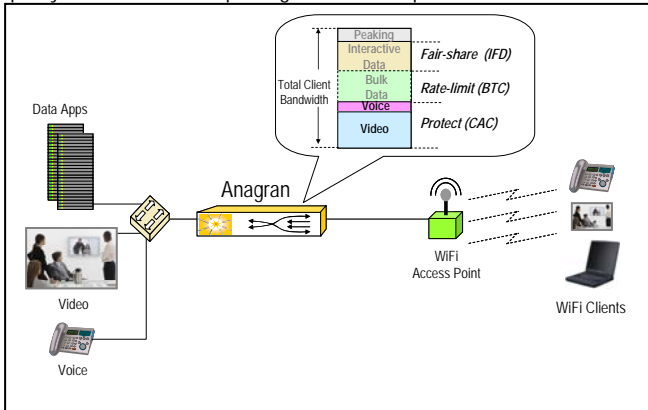

Figure 1: With Anagran, voice and video work over WiFi.

As shown in Figure 1 above, Anagran operates as a simple drop in solution that precisely controls the rate of each flow resulting in protection of voice and video traffic while allowing maximum efficiency for the rest of the traffic over the WiFi network.

Testing conducted for video and voice quality over WiFi networks reveals that with Anagran inserted, video and voice quality is preserved as more flows are injected into the test network. See the following figures:

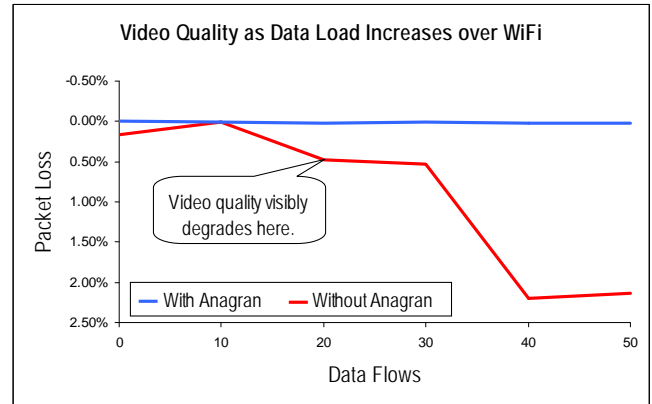

Figure 2: Video quality is sustained with Anagran.

Without Anagran, video quality visibly degrades after just 20 additional data flows (.05% packet loss or greater results in visible quality drop).

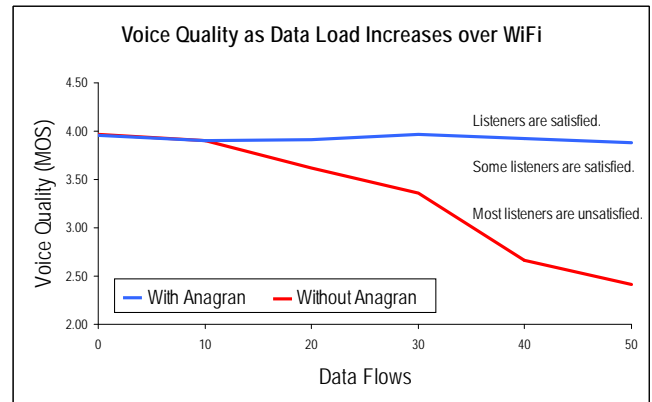

Figure 3: Voice quality is sustained with Anagran.

Without Anagran, voice quality indicated by the Mean Opinion Score (MOS) value, rapidly declines after just 10 additional data flows.

### **ANAGRAN FEATURE SPOTLIGHT** Protecting Streaming Voice and Video Quality ... All the Time

#### Rate Control

- Keeps aggregate traffic load from contending applications from damaging voice and video

#### Intelligent Flow Discard (IFD)

- Provides Call Admission Control (CAC) for streaming video and voice
- Paces TCP and other competing traffic to keep it from impacting real-time traffic

#### Behavioral Traffic Control

- Further protects real-time traffic by throttling down Bulk and P2P traffic rate

#### Conclusion:

Anagran Fast Flow Technology™ allows packet networks to easily overcome the limited bandwidth and inflexible QoS challenges that plague voice and video over WiFi networks. With Anagran, sustained voice and video quality over WiFi is guaranteed, regardless of how busy the network.

*For the first time, high-quality voice and video over WiFi can be offered with confidence!*